

THIS MAP IS FOR ASSESSMENT PURPOSES. IT IS NOT VALID FOR LEGAL DESCRIPTION OR CONVEYANCE.

THE HORIZONTAL DATUM IS THE NEW HAMPSHIRE STATE PLANE COORDINATE SYSTEM, NAD 83.

PHOTOGRAPHY DATE: APRIL 25, 2003

COMPLETION DATE: FEBRUARY 2004

PRODUCED IN 2004 BY

CAI Technologies
Precision Mapping. Geospatial Solutions.

11 PLEASANT STREET, LITTLETON, NH 03661
800.322.4540 - WWW.CAI-TECH.COM

LEGEND

AREA SURVEYED	Ac	NO WINTER MAINTENANCE	---
AREA CALCULATED	AcC	EXEMPT PROPERTY	②
RECORD DIMENSION	100'	SUBDIVISION LOT NO.	①
SCALED DIMENSION	100'S	BUILDING	▭
MATCH LINE	M.L.	RIGHT OF WAY/ACCESS	R/W
WATER	W	COMMON OWNERSHIP	---
		WETLANDS	W

SCALE 1" = 400'

FEET: 200 0 400 800 1200

METERS: 100 0 100 200 300

REVISED TO :

PROPERTY MAPS

EFFINGHAM

NEW HAMPSHIRE

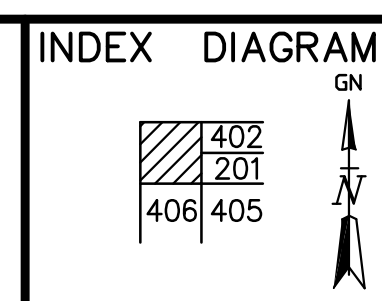

MAP NO.

401